

5 FRAMING CONNECTION
(REQ'D. IF IT'S LONGER THAN 21'-0")

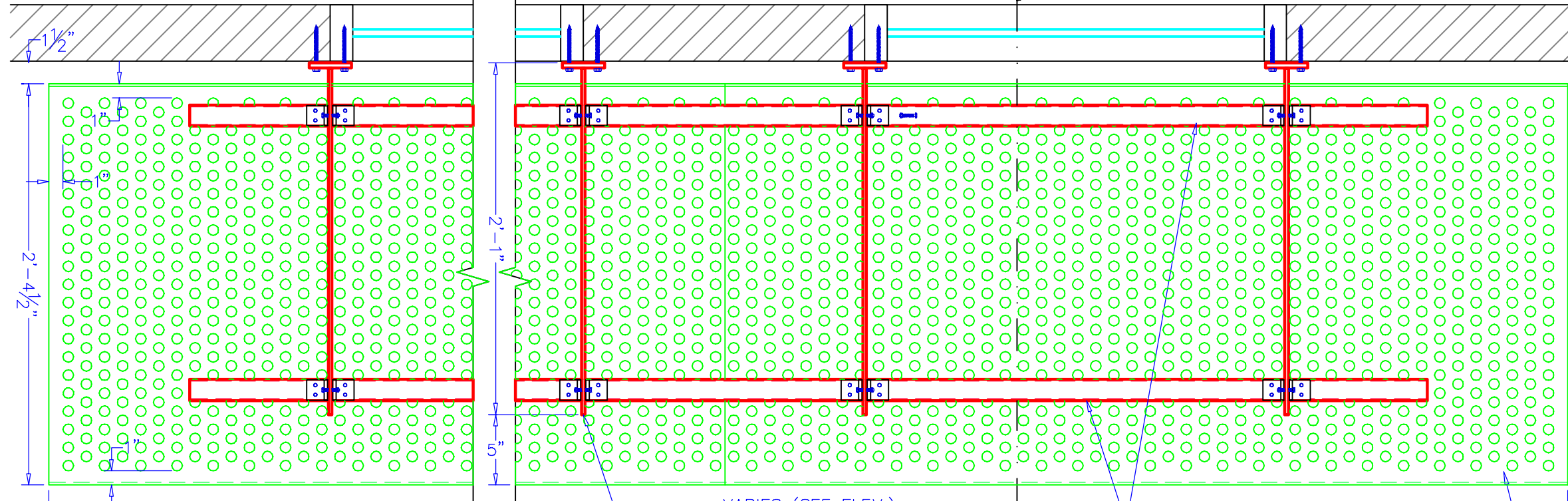

3 ALUM. SUNSCREEN

(4) 1/2"ØX5" LAG BOLTS W/ NEOPRENE WASHERS
3/4"ØX1" SPACERS @ LAP SIDING/PLASTER LOCATIONS

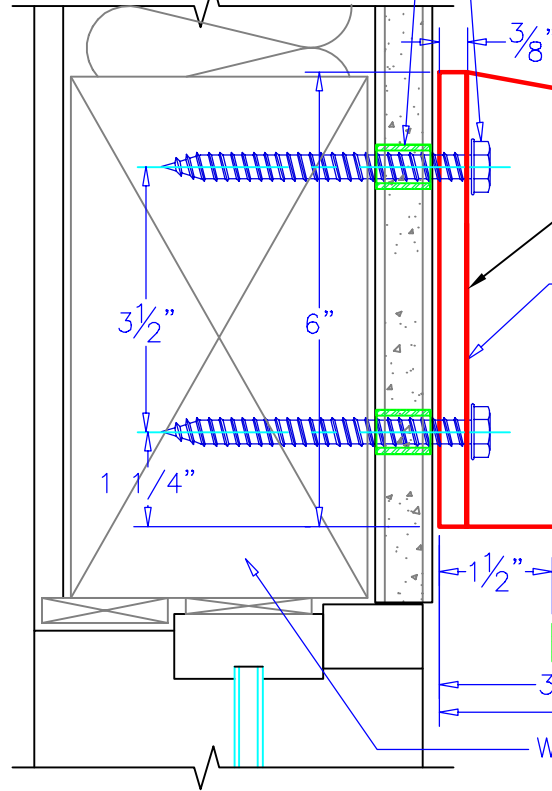

4 SECTION SUNSCREEN

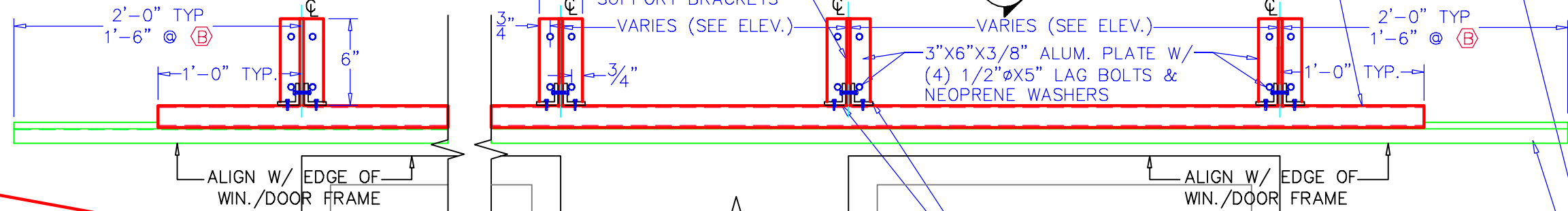

ELEVATION

4

PLAN

B & C AWNING, INC.
3082 EAST MIRALOMA AVE.
ANAHEIM, CA 92806
TEL: (714) 632-3303
FAX: (714)632-5632

JOB NAME: HOUSING ADMINISTRATION OFFICE BLDG #31
26070 CAL POLY TECHNIC STATE UNIVERSITY
SAN LUIS OBISPO, CA 93407
CONSTRUCTOR: ---

DATE: -/-/-
SHEET NO.: -/-

THESE SHOP DRAWINGS ARE PRESENTED IN ORDER TO MORE PERFECTLY AGREE, THEY DEFINE IN DETAIL B & C AWNINGS SCOPE OF WORK, THEY BECOME THE FINAL DEFINITIVE AGREEMENT, COMPLETE INVENTORY OF WHAT BUYER/AGENT/CONTRACTOR AGREES TO BUY, SUPERSEDE ALL PLANS, SPECIFICATIONS PRIOR TO APPROVAL DATE. IN APPROVING/ STAMPING THESE DRAWINGS AGENT/BUYER AGREES TO ABOVE STATEMENTS ALSO AGREES CLAIMS AGAINST B & C AWNINGS INC. THEIR HEIRS AND ASSIGNEES TO INDEMNIFY AGENT/ CONTRACTOR, PAY ATTORNEY FEES OR DEFEND AGAINST LEGAL ACTIONS ASSOCIATED OR EMANATING THERE FROM IS LIMITED TO THE WARRANTY PERIOD PROVIDED HEREIN, FUTURE UNRESOLVED DISPUTES BEING ADDRESSED IN THE ORANGE COUNTY COURT JURISDICTION AS FORUM.